

Container Security Initiatives At Seaports

Presented by

eModal

Port Security Seminar
Seattle, WA
July 20, 2006



Alliance of the Ports of Canada, the Caribbean, Latin America and the United States



eModal Today



32 marine terminals
12 Major Port Complexes
More than 14,000 registered users
3.9 million container views per month

Common Portal – Data Feeds

Mapping Provided

MTO Frequency Levels

FTP, Webservices



315
301



315
301



315
301



315
301



315
301



315
301

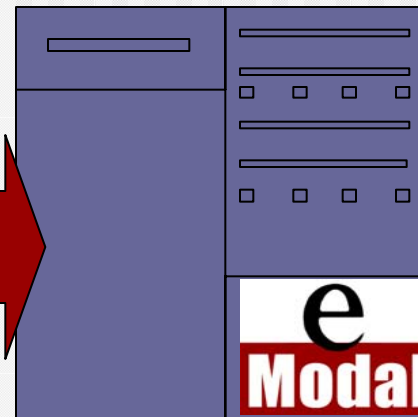



Import Containers

Container:

Select	Container	Terminal	Available	Customs	Fees	Freight	In Yard	La	Size/Type	Vessel	Voyage	Load/Empty
<input type="checkbox"/>	APZU3080631	PNCT	YES	RELEASED		PAID	G	7/18/2006	20~ DF	VLU	127E	L
<input type="checkbox"/>	BAFU8894734	SCSPA							20~ DF		007W	L
<input type="checkbox"/>	CARU9636630	NIT	YES	RELEASED		PAID	W		40~ D	MAERSK ROTTERDAM	548W	L
<input type="checkbox"/>	CCLU4446630	PNCT	NO	RELEASED		PAID	OG	7/14/2006	40~ DF	Unknown Vessel	247E	L
<input checked="" type="checkbox"/>	XU1436785	PIER400	NO	RELEASED	\$225.00	PAID	W	7/13/2006	20~ DF	MAERSK GIRONDE	0615	L
<input type="checkbox"/>	GESU5025032	SCSPA	YES				G		40~ DF		00610W	L
<input type="checkbox"/>	GESU5025032	MSK-CHS	NO	HOLD		DUE	G		40~ DF 9~6"	Sealand Commitment	0610	L
<input type="checkbox"/>	GLDU2940833	PNCT	YES	RELEASED		PAID	G	7/17/2006	20~ DF	CSCL MELBOURNE	009W	L
<input type="checkbox"/>	HLXU4162336	NIT	YES	RELEASED		PAID	G		40~ DF	NYK KAI	084W	L
<input type="checkbox"/>	KNLU3375336	SCSPA	YES									
<input type="checkbox"/>	MOLU2740336	TRPLA	YES				OV	7/18/2006		MOL ENTERPRISE	027W	
<input type="checkbox"/>	MSCU4702038	NIT	YES	RELEASED		PAID	W		40~ DF	MAERSK ROTTERDAM	548W	L
<input type="checkbox"/>	SUDU4586732	SCSPA	YES				G		40~ DF	CSAV CHICAGO	060N	L
<input type="checkbox"/>	TRLU3196893	PIER400	NO	RELEASED	\$1,575.00	PAID	W	7/3/2006	20~ DF	SEA-LAND CHARGER	0612	L
<input type="checkbox"/>	TTNU9759085	PIER400	NO	RELEASED	\$675.00	PAID	W	7/11/2006	40~ DF 9~6"	KNUD MAERSK	0612	L
<input type="checkbox"/>	YMLU2711531	NIT	NO				W		20~ DF	UNKN	n/a	E
<input type="checkbox"/>	YMLU4512734	ITS	YES	RELEASED	\$0.00	PAID	W	7/14/2006	40~ DF	GENOA BRIDGE	24	L
<input type="checkbox"/>	YMLU4847738	ITS	YES	RELEASED	\$0.00	PAID	G	7/14/2006	40~ DF	GENOA BRIDGE	24	L



Import Containers

- Home
- Scheduler
- Pay Fees
- Send Page
- Print
- Note
- Add
- Delete
- Customize
- Notifiers
- VCY

Container:

Select	Container	Terminal	Available	Customs	Fees	Freight	Last Free Day	Size/Type	Vessel	Voyage	Load/Empty
<input type="checkbox"/>	APZU3080631	PNCT	YES								
<input type="checkbox"/>	BAFU8894734	SCSPA									
<input type="checkbox"/>	CARU9636630	NIT	YES								
<input type="checkbox"/>	CCLU4446630	PNCT	NO								
<input type="checkbox"/>	CRXU1436785	PIER400	NO								
<input type="checkbox"/>	GESU5025032	SCSPA	YES								
<input type="checkbox"/>	GESU5025032	MSK-CHS	NO								
<input type="checkbox"/>	GLDU2940833	PNCT	YES	RELEASED		PAID	G	7/17/2006	20~ DF	CSCL MELBOURNE	009W L
<input type="checkbox"/>	HLXU4162336	NIT	YES	RELEASED		PAID	G		40~ DF	NYK KAI	084W L
<input type="checkbox"/>	KNLU3375336	SCSPA	YES								
<input checked="" type="checkbox"/>	LU2740336	TRPLA	YES				OV	7/18/2006		MOL ENTERPRISE	027W
<input type="checkbox"/>	MSCU4702038	NIT	YES	RELEASED		PAID	W		40~ DF	MAERSK ROTTERDAM	548W L
<input type="checkbox"/>	SUDU4586732	SCSPA	YES				G		40~ DF	CSAV CHICAGO	060N L
<input type="checkbox"/>	TRLU3196893	PIER400	NO	RELEASED	\$1,575.00	PAID	W	7/3/2006	20~ DF	SEA-LAND CHARGER	0612 L
<input type="checkbox"/>	TTNU9759085	PIER400	NO	RELEASED	\$675.00	PAID	W	7/11/2006	40~ DF 9~6"	KNUD MAERSK	0612 L
<input type="checkbox"/>	YMLU2711531	NIT	NO				W		20~ DF	UNKN	n/a E
<input type="checkbox"/>	YMLU4512734	ITS	YES	RELEASED	\$0.00	PAID	W	7/14/2006	40~ DF	GENOA BRIDGE	24 L
<input type="checkbox"/>	YMLU4847738	ITS	YES	RELEASED	\$0.00	PAID	G	7/14/2006	40~ DF	GENOA BRIDGE	24 L

Scheduler Receipt
Scheduler number: I9372951
Container: CRXU1463587
Terminal: ITS
Sched Date: 07/21/06 09:00-10:00

Acceptance and eModal Use by the Trucking Community

Approximately 4,000 trucking companies across the United States are registered in the eModal PCS.

eModal Trucker Check



Alliance of the Ports of Canada, the Caribbean, Latin America and the United States



TRUCKER INFORMATION

All fields are required.

First Name:

Last Name:

Trucker is Active.

Click on the box to activate. If you wish to deactivate a trucker, click to remove the check.

Driver License Number:

State/Province:

Expiration Date (mm/dd/yyyy):

Trucker is contracted to haul for this trucking company for the following period:

Contract doesn't have expiration date.

Contract Begin:
(mm/dd/yyyy)

Contract End:
(mm/dd/yyyy)

Indicate trucker certifications	Yes	No
Class A	<input type="checkbox"/>	<input type="checkbox"/>
Class B	<input type="checkbox"/>	<input type="checkbox"/>
Haz/Mat	<input type="checkbox"/>	<input type="checkbox"/>
Tankers	<input type="checkbox"/>	<input type="checkbox"/>
Doubles	<input type="checkbox"/>	<input type="checkbox"/>
Triples	<input type="checkbox"/>	<input type="checkbox"/>

What port(s) will this trucker call:

- PierPASS TruckTag for Ports of LA & LB
- Port of Seattle
- Port of Oakland
- Port of Baltimore

Continue

Cancel

Click on an announcement for more details.

[Logoff](#)[Activity Folder](#)[Scheduler](#)[Fee Payment](#)[Trucker Check](#)[EDO](#)[My eModal](#)[Contact Us](#)

TRUCKER CONSENT AUTHORIZATION

As a registered user of www.emodal.com, I am submitting a driver's information to this system and site, and I warrant and represent that the driver has given to me written consent to obtain such information and to transmit it to eModal.com, LLC. for dissemination to eModal's registered users, in accordance with the provisions of the Driver's Privacy Protection Act, 18 U.S.C. Article 2721 et seq. I further warrant and represent that I have advised the driver that such information may include the following: driver's first and last name, driver's license number, driver's license expiration date and state of issue, truck license plate numbers, contract period with me as well as the names of the companies who have registered the same drivers with eModal.

This registered company also warrants and represents that the driver whose information is being submitted has provided me with proof that he/she has a valid commercial driver's license as required by law.

TRUCK LICENSE PLATE NUMBER

Please enter the truck license plate number for this trucker Bob Jones (Lic: UL989098).

Truck License Plate Number:

State/Province:



Is this the only license plate on the front bumper of this truck? Yes No

This truck will need a RFID tag to go to:

- PierPASS TruckTag for Ports of LA & LB
- Port of Seattle
- Port of Oakland

- I do NOT need a RFID tag.

[Home](#) | [Directory](#) | [About Us](#) | [Help](#)

APMTerminals Daily Update Thursday 04-06-2006

MULTIPLE TRUCKS

This trucker Bob Jones (Lic: UL989098) can drive the following truck(s).

RFID	Plate	Additional Plate(s)	RFID Tag Infor
Pending	CAfi98634		Delete Requested by eModal on 04/06/2006

Will this trucker drive other trucks for your company to the port? Yes No

eModal Trucker Check

ACTIVE TRUCKER - The trucker Bob Jones (Lic: UL989098) is now registered with your company as **ACTIVE** trucker.
The terminals will be updated.

Please select the type of drivers you want to view:

Then click on [View All Truckers](#) or the first letter of truck drivers last name:

[A](#) [B](#) [C](#) [D](#) [E](#) [F](#) [G](#) [H](#) [I](#) [J](#) [K](#) [L](#) [M](#) [N](#) [O](#) [P](#) [Q](#) [R](#) [S](#) [T](#) [U](#) [V](#) [W](#) [X](#) [Y](#) [Z](#)

To input a RFID tag number by trucker, select the trucker's name.

OR

To input a RFID tag number by truck license plate, [click here](#)

Trucking companies can review their registered truckers.

		<u>Trucker</u>	<u>License Number</u>	<u>State</u>	<u>License Expires</u>	<u>Last Update</u>	<u>More</u>
Edit	RFID	Acevedo, Denis	D4654534	CA	2/23/2008	4/5/2006 4:32:28 PM	
Edit	RFID	Acosta, Walter Anibal	N9088829	CA	5/31/2009	4/6/2006 3:07:14 PM	
Edit	RFID	Aguayo, Ramon Rosales	A8696431	CA	3/28/2008	4/11/2006 9:29:45 AM	
Edit	RFID	Aguila, Rolando De Paz Del	C6368960	CA	10/31/2008	4/4/2006 10:16:41 AM	
Edit	RFID	Aguilar, Jose Luis	A3006931	CA	4/27/2010	5/15/2006 11:01:34 AM	
Edit	RFID	Aguilar, Rodrigo	A1806323	CA	10/29/2007	4/6/2006 8:32:35 AM	
Edit	RFID	Aguilar, Santiago Armando	C5570616	CA	7/4/2006	1/24/2006 11:54:43 AM	
Edit	RFID	Aguirre, Juan Carlos	A8365356	CA	5/16/2010	4/4/2006 2:07:52 PM	
Edit	RFID	Aguirre, Miguel Angel	B7898189	CA	9/5/2008	1/24/2006 2:37:42 PM	
Edit	RFID	Aguirre, Norma	A1677205	CA	10/21/2007	4/5/2006 4:41:17 PM	

Trucker Check Process

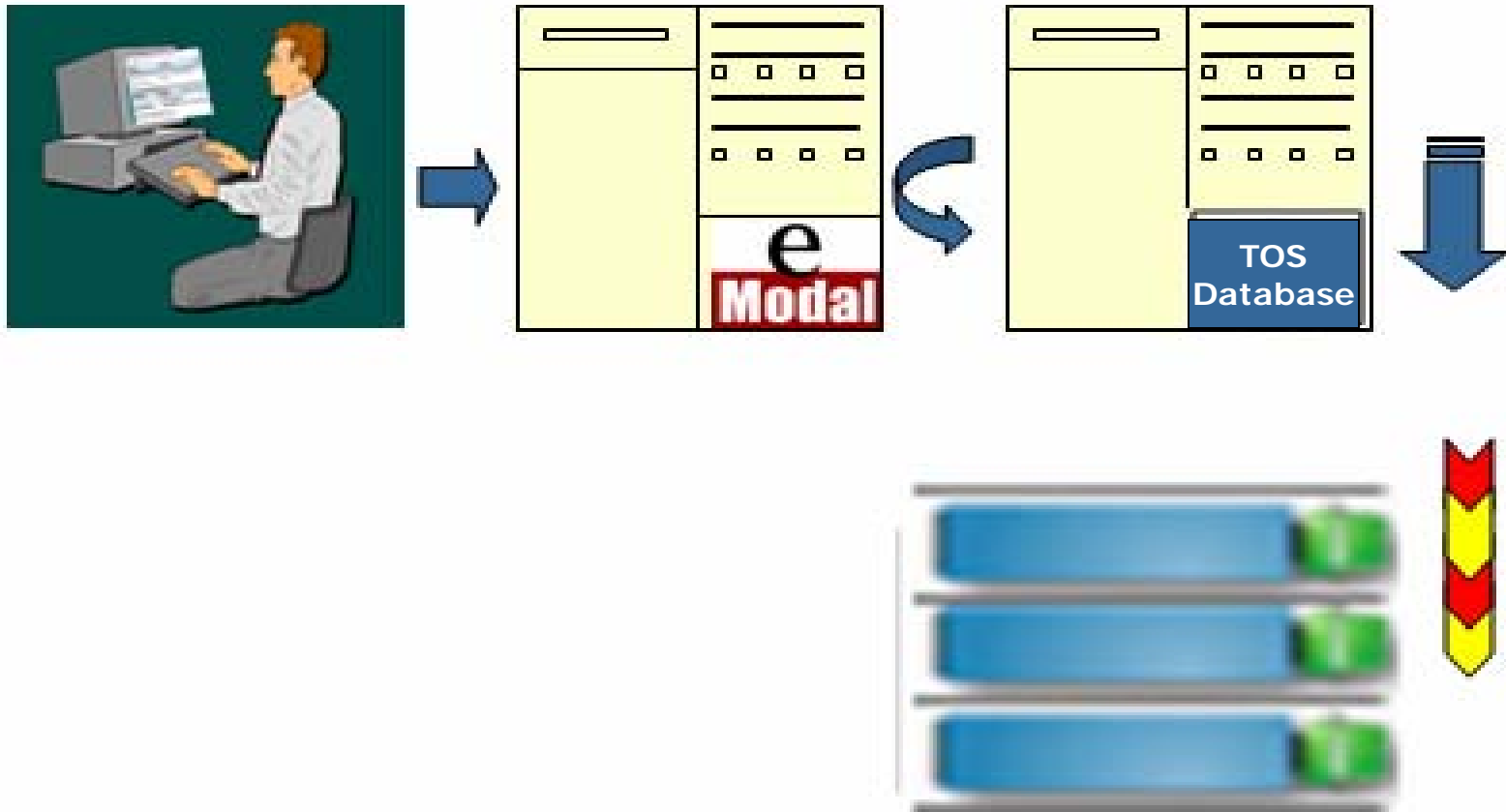

In use at marine terminals in

- Port of Baltimore
- Port of Long Beach
- Port of Los Angeles
- Port of Oakland
- Port of Seattle

Top News

Feb 14, 2006 11:46 pm US/Eastern

New Security Measures At Port Of Baltimore



Kai Jackson
Reporting

- Save It
- Email It
- Print It

(WJZ) BALTIMORE There are new security measures being taken at the Port of Baltimore beginning Wednesday. All trucks and drivers entering the port's terminal truck gates will be entered into a new consolidated database. "When that driver comes in, we'll ask him who he's driving for, what his tag number is or what his identification number is, what his name is, and we'll be able to tell if that truly is the driver that's supposed to be there to pick up the container or not," Deputy Transportation Security Jim Ports tells WJZ's Kai Jackson.

The new technology's aim is to identify each driver's and truck's credibility and prevent any potential terrorists from entering.

There's hundreds of people everyday coming in and out of the port through specific access points that need to be checked," says Chief of MDTA Police Gary McLhinney.

13 Video



Play New Security Measures At Port Of Baltimore

STORY TOP STORIES

Baltimore is the first east coast port to install the new system, called the "E-Modal Truck Check." It's the latest in a long line of security upgrades at the port.

Other additions include a remote video surveillance system, perimeter security upgrades, and a security patrol boat equipped with sonar.

"We can make sure that they have business on port property so the process is evolving minute by minute," says McLhinney.

"It's a homeland security measure that we're



Port of Baltimore WJZ

Track It!

Track names and topics in the news:

- Port Of Baltimore
- Homeland Security
- MDTA



Scalable Technology



- Trucker's name -last/first
- Assigned PIN
- SCAC
- DOT number
- CDL number – state/province of issue, expiration date
- Tractor plate number(s)
- Confirmation that contract is "Active."
- RFID numbers
- Container, Booking, Pick-up nos.
- Numeric identifiers - TWIC, Govt. nos.
- Verifying appt. numbers
- Biometrics/Fingerprints
- Digital photos

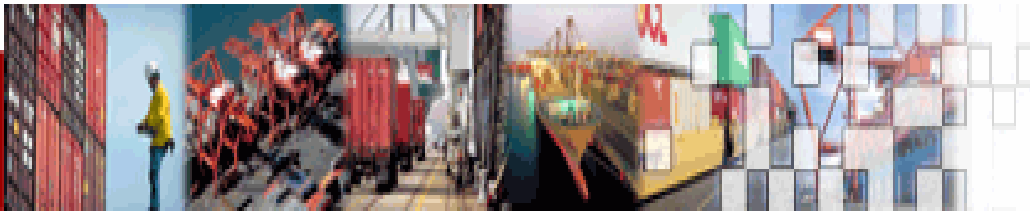

[Home](#) | [Directory](#) | [About Us](#) | [Help](#)

LBCTI Daily Terminal Update: Friday, July 14th, 2006

[Login](#)

[Activity Folder](#)

[Scheduler](#)

[Fee Payment](#)

[Trucker Check](#)

[VCY](#)

[EDO](#)

[My eModal](#)

Contact Us

Trouble logging in?

[Click here for eModal demos!](#)

[Click here to Register](#)

The eModal Port Community System brings the entire transportation industry together.

Trucker Check RFID Tags



[I Need More Tags](#)



[Where Are My Tags](#)



[More Info.](#)

LAHGT

Los Angeles Harbor
Grain Terminal

Import or Export...
Boxed, Bulk, or
Palletized...
No job too big or
too small

[Click to Advertise with eModa](#)

Didn't Get All Your Requested Tags? [Click here](#)



[RFID Tag Installation Video](#)

[RFID Tag Mounting Instructions](#)

Frequently Asked Questions

I have verified more trucks with eModal than tags sent. Where are the other tags?

How do I participate in the RFID truck tagging program?

How much does it cost to participate in the PierPASS RFID electronic tag program?

Why do I have to participate in the RFID tag program?

What if I do not put an RFID tag on my truck?

How do I know which truck to put the RFID tag on?

The tag came without parts. How do I get the parts I need?

We just received the tag but the tractor listed is no longer contracted with our company -- what should we do with the tag?

I just hired a trucker and there is already a tag on the truck. How do I activate the tag for our company?

I just hired a trucker without a tag on the truck; how do I get the trucker a tag?

The truck is no longer with my company, what should I do?

Can I transfer the tag from one truck to another?

When do they have to be on the truck?

Why is PierPASS doing this?

How do I get a tag?

What shall I do if my trucker drives for more than one company?

How do I know my trucks are validated for tags?

All our drivers use all company trucks. Where is the truck pool feature?

Our drivers deliver nationally, and come to LA/LB only occasionally.

WhereTag TD Driver's Side Mirror Mount Instructions

Please follow all steps in order.

Do not at any time press the button on the tag.

Parts as shown in Figure 1:

- Two 11" pipe clamps
- Two 4.5" pipe clamps
- Tag Mount
- WhereTag

(screwdriver not included)

Note: Only two clamps are used. Four clamps in two different sizes are provided with the kit to accommodate different sized mirror mount bars.

STEP 1 Using 2 of the provided pipe clamps, fasten the tag mount onto the top mirror bar on the driver's side as shown in Figure 2a. If there is no top mirror bar, use mirror bars shown in Figure 2b or 2c below. Use the pipe clamp size that best fits the bars. If your mirror mount is not shown, please see the following website for other examples of mirror mounts with tags correctly installed: <http://www.emodal.com/Help/TagMounting.aspx>

NOTE: Always fasten on the Driver's Side to the top bar as shown in Figure 2a.

STEP 2 Adjust the mount so it is level on the mirror bar as shown in Figure 3.

Note: The mount cannot be loosened or moved after the tag is inserted so you must precisely position and tighten mount prior to inserting the tag.

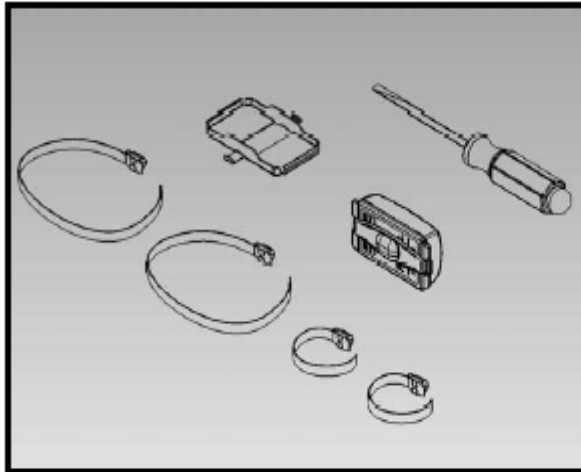

Figure 1 - Mounting Kit Parts

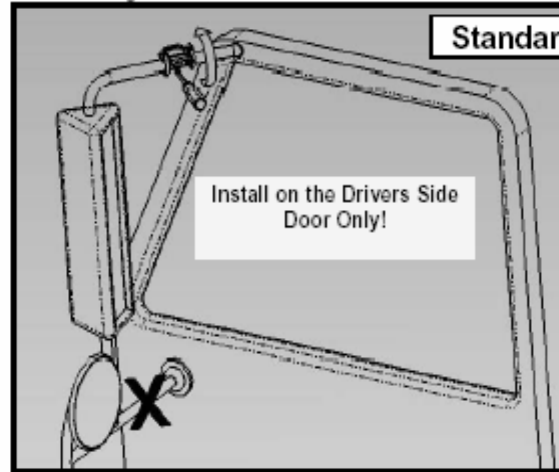

Figure 2a - Preferred Location

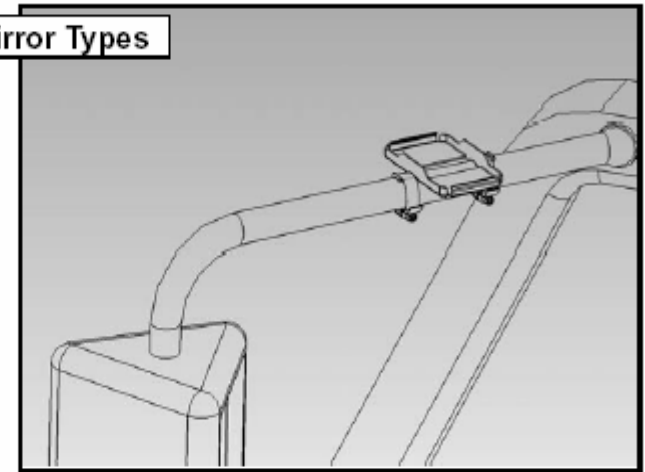

Figure 3 - Verify Level Mount

Non-Standard Single Arm Mirror Types

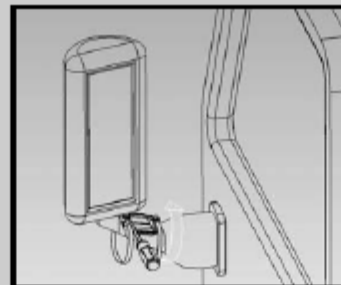

Figure 2b - Alternative Mount

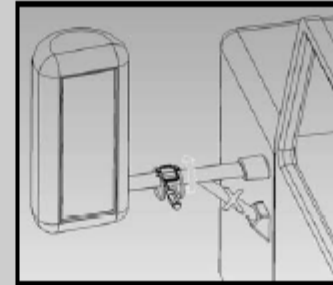



Figure 2c - Alternative Mount

↓
Proceed to Step 3

Click on an announcement for more details.

[Logoff](#)
[Activity Folder](#)
[Scheduler](#)
[Fee Payment](#)
[Trucker Check](#)
[EDO](#)
[My eModal](#)

Enter RFID Number

Trucker	License Number	State	License Expires	Last Update	More
Johnson, Bob	2435325	WA	11/18/2008	3/27/2006 5:18:05 PM	

Active Trucker

PIN: 789124678 Open Contract

RFID	Plate	Additional Plate(s)	Sent To	Sent Date
Pending	WAW90856			

Enter the truck license plate number as recorded on the RFID mounting sheet:

Truck License Plate Number:

State/Province:



Enter the LAST 5 digits of the RFID tag number as recorded on the RFID mounting sheet:

Enhancing Security
Features With Existing
eModal Trucker Check
Functionality.....
Where do we go next?



16600

AUG 18 2004

Carroll & Froelich, PLLC
Attn: Mr. F. Edwin Froelich, Esquire
2011 Pennsylvania Avenue, NW
Suite 301
Washington, DC 20006

Dear Mr. Froelich:

I am pleased to inform you of the use of RFID tags as an interim security measure to check the identification information of motor carriers at maritime facilities. Your vendor representative should be contacted for information required for truck dispatching.

The West Coast Marine Terminal (WCMT) wishes to amend their 100% identification interim security measure to include a 100% identification interim security measure. The identification interim security measure system to confirm the identification interim security measure may require additional measures, in addition to the current interim security measure. The following amendments are proposed:

- a. The use of RFID tags shall be limited to participating motor carriers and shall be filed and approved by the Coast Guard.
- b. Participating motor carriers shall be acceptable to the Coast Guard if:
 - ensure that the RFID tags are used only for the specific cargo transaction;
 - require the motor carrier to provide the Coast Guard with access upon request to the database or databases containing information on drivers covered by the program and any system or process failures or discrepancies;

- c. The required motor carrier 100% identification check shall include a check of the driver's

in the Commercial Driver's License Information System (CDLIS) maintained by the Federal Motor Carrier Safety Administration of the U.S. Department of Transportation;

- d. Trucks equipped with RFID tags will be screened at the rate stipulated in the applicable MARSEC Directives or other U.S. Coast Guard order for vehicles transporting cargo and this screening shall include a random confirmatory check of the driver's credentials against the driver registry contained in the e-Modal or equivalent database; and
- e. Participating WCMTODA members will institute, as part of the required annual audit of their information contained

• require motor carriers to provide information to the terminal operator on the specific truck unit and driver being dispatched to a participating terminal to perform a specific cargo transaction.

over the 12 month period. Participating members will still be required to pay any penalty that

technology. Any information is understood that the Transportation Worker Identification Administration (TSA)

of available information and software in the

- Encl. (1) RFID proposal dated May 18, 2004
(2) Errata sheet dated July 16, 2004
(3) Errata sheet dated August 13, 2004

Copy: Commander, Coast Guard Pacific Area (Pmr)
Commander, Coast Guard Atlantic Area (Amr)
Commander, Eleventh Coast Guard District (m)
Commander, Thirteenth Coast Guard District (m)

Select	Container	Terminal	Available	Customs	Fees	Freight	In Yard	Last Free Day	Size/Type	Vessel	Voyage	Load/Empty
--------	-----------	----------	-----------	---------	------	---------	---------	---------------	-----------	--------	--------	------------

<input type="checkbox"/>	APZU3080631	PM
<input type="checkbox"/>	BAFU8894734	SC
<input type="checkbox"/>	CARU9636630	NI
<input type="checkbox"/>	CCLU4446630	PM
<input type="checkbox"/>	CRXU1436785	PI
<input type="checkbox"/>	GESU5025032	SC
<input type="checkbox"/>	GESU5025032	MS
<input type="checkbox"/>	GLDU2940833	PM
<input type="checkbox"/>	HLXU4162336	NI
<input type="checkbox"/>	KNLU3375336	SC
<input type="checkbox"/>	MOLU2740336	TR
<input type="checkbox"/>	MSCU4702038	NI
<input checked="" type="checkbox"/>	U4586732	SC
<input type="checkbox"/>	J3196893	PI

		Trucker	License Number	State	License Expires	Last Update	More
Edit	RFID	Acevedo, Denis	D4654534	CA	2/23/2008	4/5/2006 4:32:28 PM	
Edit	RFID	Acosta, Walter Anibal	N9088829	CA	5/31/2009	4/6/2006 3:07:14 PM	
Edit	RFID	Aguayo, Ramon Rosales	A8696431	CA	3/28/2008	4/11/2006 9:29:45 AM	
Edit	RFID	Aguila, Rolando De Paz Del	C6368960	CA	10/31/2008	4/4/2006 10:16:41 AM	
Edit	RFID	Aguilar, Jose Luis	A3006931	CA	4/27/2010	5/15/2006 11:01:34 AM	
Edit	RFID	Aguilar, Rodrigo	A1806323	CA	10/29/2007	4/6/2006 8:32:35 AM	
Edit	RFID	Aguilar, Santiago Armando	C5570616	CA	7/4/2006	1/24/2006 11:54:43 AM	
Edit	RFID	Aguirre, Juan Carlos	A8365356	CA	5/16/2010	4/4/2006 2:07:52 PM	
Edit	RFID	Aguirre, Miguel Angel	B7898189	CA	9/5/2008	1/24/2006 2:37:42 PM	
Edit	RFID	Aguirre, Norma	A1677205	CA	10/21/2007	4/5/2006 4:41:17 PM	



<input type="checkbox"/>	TTNU9759085	PI										
<input type="checkbox"/>	YMLU2711531	NIT	NO				W		20~ DF	UNKN	n/a	E
<input type="checkbox"/>	YMLU4512734	ITS	YES	RELEASED	\$0.00	PAID	W	7/14/2006	40~ DF	GENOA BRIDGE	24	L
						PAID	G	7/14/2006	40~ DF	GENOA BRIDGE	24	L

Scheduler Receipt

Scheduler number: **I9372951**

Container: CRXU1463587

Terminal: ITS

Sched Date: 07/21/06 09:00-10:00



Trucker's name:
Last/first
Assigned PIN
SCAC
DOT number
CDL number:
state/province
expiration date

RFID numbers
Confirmation of "Active"
Tractor plate number(s)
Container, Bkng, Pick-up nos.
Numeric IDs - TWIC, Govt. nos.
Verifying appt. numbers
Biometrics/Fingerprints
Digital photos

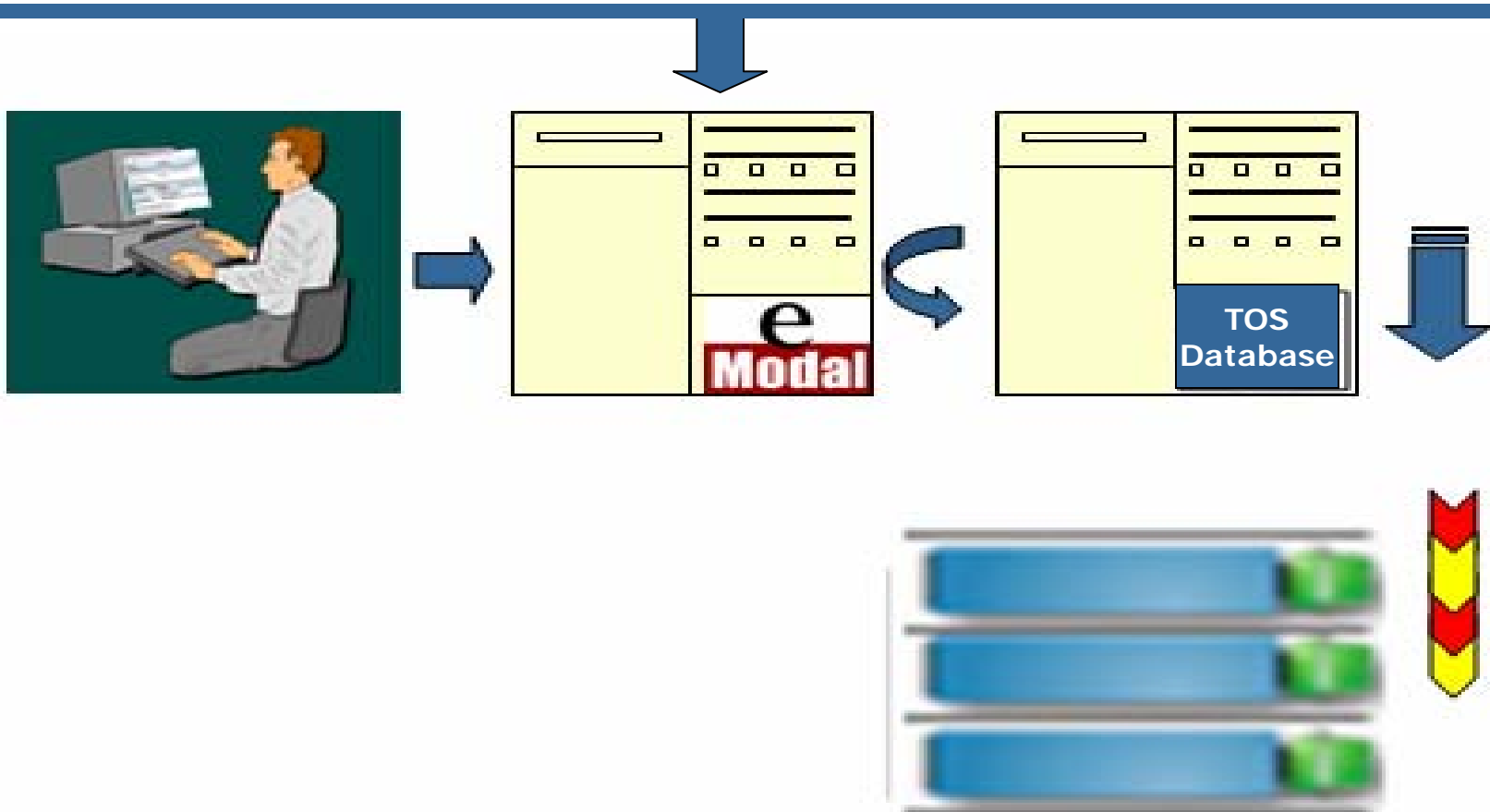

Thank you
Questions/Comments/Discussion